

Gravi-Tech™ Density Modified Formulations



TABLE OF CONTENTS

| | |
|--|----|
| Chapter 1. Product Summary | 5 |
| Chapter 2. Process Settings | 6 |
| Chapter 3. Part Design Guidelines | 8 |
| Wall Thickness | 8 |
| Minimizing Sinks | 8 |
| Draft | 8 |
| Rib Design Guidelines | 9 |
| Boss Design Guidelines | 9 |
| Structural Hole Design Guidelines | 10 |
| Non-Structural Hole Design Guidelines | 11 |
| Snap Fits | 11 |
| Press Fits | 11 |
| Mechanical Fasteners | 12 |
| Adhesive Types | 13 |
| Chapter 4. Mold Design Guidelines | 14 |
| Cold Runner Layouts | 14 |
| Runner Sizing and Design | 14 |
| Hot Runner Layouts | 14 |
| Gate Sizing and Locations | 16 |
| Gating Types – Manual Trim Gates | 16 |
| Cooling Layouts | 18 |
| Ejection | 18 |
| Venting | 19 |
| Chapter 5. Process Optimization | 20 |
| Machine Sizing | 20 |
| Four Main Plastic Variables | 20 |
| Establishing a Process – The Scientific Molding Method | 21 |
| Process Distinctions | 23 |

| | |
|---|----|
| Chapter 6. Troubleshooting | 25 |
| Four Main Areas..... | 25 |
| Obtain Information..... | 25 |
| Strategy Theory..... | 25 |
| Defects..... | 26 |
| Angel Hair..... | 26 |
| Burns..... | 28 |
| Delamination..... | 29 |
| Dimension – Small..... | 30 |
| Dimension – Large..... | 31 |
| Distortion / Deformation..... | 32 |
| Flash..... | 33 |
| Jetting..... | 34 |
| Plate-Out..... | 35 |
| Short Shot..... | 36 |
| Sink..... | 37 |
| Splay..... | 38 |
| Surface Finish..... | 39 |
| Gate Vestige..... | 40 |
| Voids..... | 41 |
| Warpage..... | 42 |
| Weld Lines..... | 43 |
| | |
| Appendix | 44 |
| The Injection Unit..... | 44 |
| Non-Return Valves..... | 44 |
| Nozzle Types..... | 45 |
| Important Advice..... | 45 |
| The Clamping Unit..... | 45 |
| Mold Design Guidelines..... | 47 |
| Determining Cooling Time..... | 48 |
| Cooling Line Spacing..... | 49 |
| Bibliography..... | 51 |
| Acknowledgments..... | 51 |



GRAVI-TECH™ DENSITY MODIFIED FORMULATIONS

High-Performance Alternative to Lead and Other Traditional Metals

PRODUCT DESCRIPTION

Gravi-Tech™ polymer-metal composites offer a high-performance thermoplastic-based alternative to lead and other traditional dense metals. Using a variety of metallic fibers and particles, these compounds have densities similar to traditional metals, while offering design and processing flexibility because of the polymer matrix, which can be extruded, molded, calendered, or thermoformed into the final desired shape.

VALUE SOLUTION

Improve safety and reduce costs with Gravi-Tech formulations

When Gravi-Tech polymer metal composites are substituted for lead, manufacturers can avoid the regulatory, disposal and employee exposure challenges associated with lead. Several grades of Gravi-Tech composites used for radiation-shielding applications provide protections similar to traditional lead-based materials, yet these Gravi-Tech polymer-metal composites are 37 percent lighter. Other radiation-shielding grades are available that match the density of lead (11 gm/cm³).

KEY CHARACTERISTICS

The primary features and benefits of Gravi-Tech formulations are:

- **Customized density**, offering a wide range of specific gravities from 1.5 to 11 gm/cm³
- **Broad modulus range**, from very flexible to very rigid grades
- **Corrosion resistance**, withstanding oxidation for long-term use and benefit
- **Chemical resistance**, withstanding fuels, oils and other harsh chemicals

Additional features include:

- Design flexibility and processing ease
- Good impact strength
- Elevated heat deflection temperature

CHAPTER 2 | PROCESS SETTINGS

Density Modified Formulations

Gravi-Tech™ polymer-metal composites are high-density materials developed as thermoplastic-based alternatives to lead and other traditional metals. These materials have been formulated using select metallic fillers and engineered thermoplastic resins to have densities similar to actual metals, while also providing the design flexibility and processing ease of conventional thermoplastics.

Injection Molding Parameters

These recommendations are regarded as a general starting point. Every molding machine is different in actual performance. Small quantities should be tested before large quantities are used. Actual temperatures should be measured using a pyrometer.

Comments

1. A higher injection velocity is needed when processing Gravi-Tech due to the thermal conductivity of the material.
2. General purpose screws work well.

| Base Resin | ABS | PA | PBT | PC | PE | PEEK | PP | PPS | |
|--------------------------------------|--------------------------------------|--------------------------------------|---------------------------------------|----|---------------------------------|----------------------|---------------------------------|----------------------|---------------------------------------|
| Barrel Temperatures °F (°C) | | | | | | | | | |
| Rear Zone | 400–475 (200–250) | 480–540 (248–282) | 480–520 (250–270) | | 480–570 (250–300) | 400–445 (200–230) | 660–700 (350–475) | 400–440 (200–225) | 520–600 (270–300) |
| Center Zone | 410–480 (205–253) | 490–550 (254–287) | 485–525 (251–273) | | 500–580 (260–305) | 410–455 (207–237) | 670–710 (357–385) | 410–450 (205–230) | 550–610 (285–310) |
| Front Zone | 420–490 (210–257) | 500–560 (260–293) | 490–530 (254–276) | | 515–590 (267–310) | 420–465 (213–243) | 680–720 (363–400) | 420–455 (215–235) | 570–620 (300–320) |
| Nozzle | 425–500 (215–260) | 510–570 (265–298) | 490–540 (254–282) | | 530–600 (275–315) | 430–475 (220–250) | 700–730 (370–395) | 430–460 (220–240) | 610–620 (320–325) |
| Melt Temperature | 425–515 (215–270) | 510–570 (265–298) | 490–540 (254–282) | | 530–615 (275–325) | 430–495 (220–260) | 700–725 (370–385) | 430–475 (220–250) | 610–635 (320–335) |
| Mold Temperature | 140–200 (60–90) | 150–300 (65–148) | 140–280 (60–137) | | 160–240 (70–115) | 80–140 (25–60) | 300–400 (150–200) | 80–140 (25–60) | 190–300 (90–150) |
| Drying Parameters | 190 (90) 2–4 Hours 0.01%–0.15% | 180 (82) 4–5 Hours 0.10%–0.20% | 275 (135) 3–4 Hours 0.02%–0.04% | | 250 (125) 3–4 Hours 0.02% | 160 (70) 2 Hours | 300 (150) 3–4 Hours 0.10% | 160 (70) 2 Hours | 280 (135) 2–3 Hours 0.01%–0.20% |
| Nozzle Type | General Purpose | Nylon or Reverse Taper | General Purpose | | General Purpose | General Purpose | General Purpose | General Purpose | General Purpose |
| Injection Velocity ¹ | 2–5 in/sec; 50–127 mm/sec | | | | | | | | |
| Injection Pressure | 1,000–2,000 psi; 7–14 Mpa | | | | | | | | |
| Back Pressure | 50–100 psi; 0.3–0.7 Mpa | | | | | | | | |
| Screw Speed | 25–75 RPM | | | | | | | | |
| Cushion | 0.125–0.250 in; 3–6 mm | | | | | | | | |
| Screw Compression Ratio ² | 2.0:1–2.5:1 | | | | | | | | |

CHAPTER 3 | PART DESIGN GUIDELINES

WALL THICKNESS

Uniform wall thickness will achieve a uniform cooling, fill, and shrink rate. All walls should be the same thickness except for ribs, bosses, snap-fits, and interlocks. Wall thickness should be as thin as possible for the application. It should be dictated by the structural and flow requirements of the part. The minimum wall thickness for a Gravi-Tech part should be no less than 0.080" (20.32 mm). The wall thickness of the part will dictate the cooling time as seen in figure 1.¹

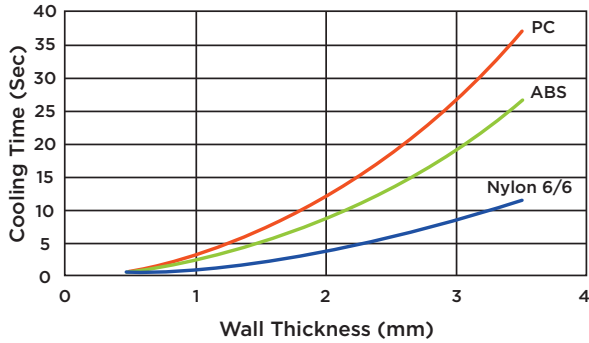

FIGURE 1 - Wall thickness vs. cooling time of various plastics

When designing for even wall thickness, it is important to transition the wall thickness using rounds or radiuses. Figure 2 shows the proper way to transition different wall thicknesses.

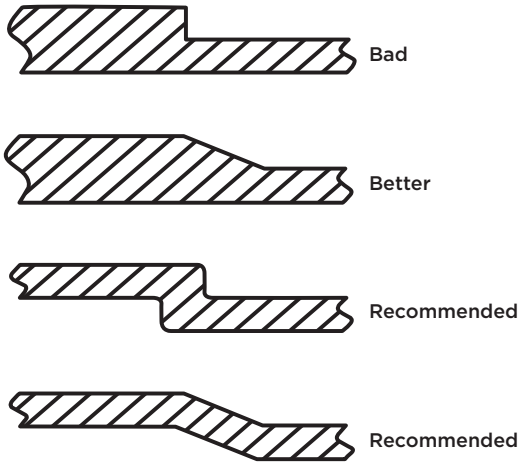

FIGURE 2 - Designing for wall thickness changes

Figure 3 shows the guidelines to use for internal and external radius. These radiuses need to be concentric. Figure 3 shows how the wall thickness can suddenly change when outside and inside rounds are not concentric.

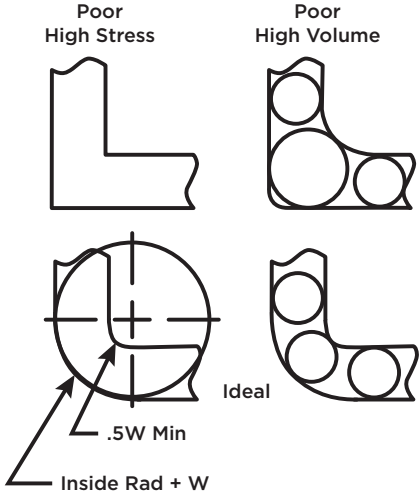

FIGURE 3 - Internal and external radius guidelines

MINIMIZING SINKS

The easiest way to avoid sinks is by minimizing thick regions in the part. The wall thickness (W) for ribs and bosses should be 75% of the nominal wall (.75W). The radius of an interior round should be at least 50% of wall thickness (.50W). The outside round should be the inside radius plus wall thickness (IR + W). All interior and exterior rounds need to be concentric.¹

DRAFT

The draft on a part is a taper on the walls perpendicular to the parting line to allow the part to release from the mold. Usually it is 2° for parallel walls, however non-parallel walls should be 1/2°. Part walls need to remain parallel when adding draft. One thing to avoid in adding draft are large variations in wall thickness. Figure 4 shows how to properly draft a part to keep a nominal wall thickness.

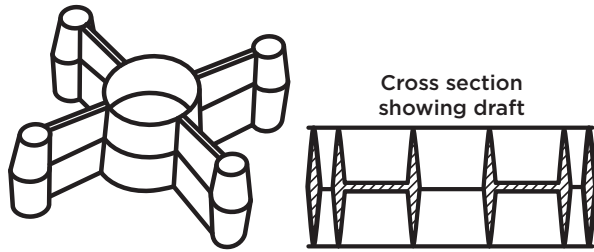

FIGURE 4 - Drafting guidelines for nominal wall thickness

RIB DESIGN GUIDELINES

The minimum distance ribs should be spaced is three times the nominal wall thickness ($3W$). The maximum height should be about 2.5 times the nominal wall thickness ($2.5W$). The width of a rib will be different depending on material used. It should be 75% of wall thickness for a low shrink material, and 50% of wall thickness for a high shrink material. The round located at the base of a rib should be 25% of nominal wall thickness, and all ribs should have a draft angle from $1/4^\circ$ – 1° . The design of a rib should be derived from the structural, flow, and assembly requirements of the part.¹

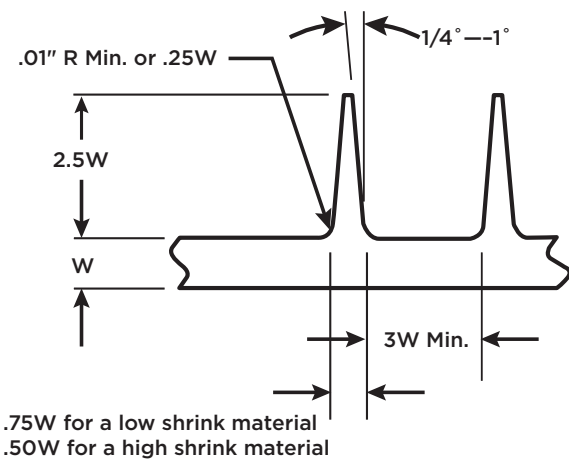

FIGURE 5 - Rib design guidelines

The height of a rib will greatly influence the stiffness. The graph in Figure 6 shows the maximum amount of displacement versus the height of the rib. At lower rib heights the maximum amount of displacement is much greater than those at higher rib heights.

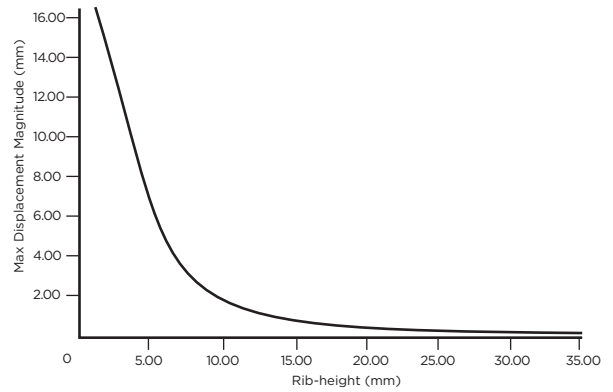

FIGURE 6 - Rib height vs. stiffness

Ribs will also cause a larger wall thickness throughout the part. Figure 7 shows how the rib creates a thick region within the part. These regions are excellent for ejector pins due to the increased surface area.

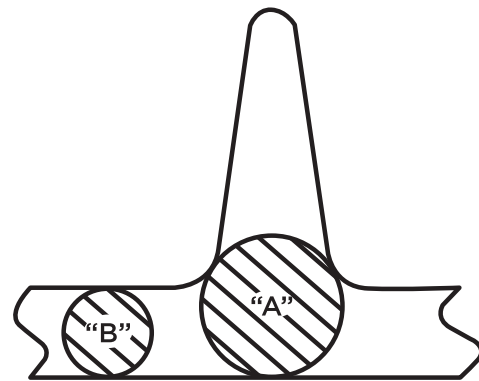

FIGURE 7 - Wall thickness changes due to rib placement

BOSS DESIGN GUIDELINES

A boss design should be dictated by the core being used and the wall thickness of the part. The inside diameter of the boss should be the diameter of the core or screw being used, depending on the type of fit desired, interference or clearance. The outside diameter of the boss should be 2.5 times the inside diameter of the core. The height of the boss should be 2.5 times the inside diameter of the boss. There should be a round at the intersection of the boss and the nominal wall with a size of 25% of wall thickness. The boss should extend into the nominal wall of the part, to avoid a thick region and possible sink

area. The round at the bottom of the boss should be 10% of wall thickness. Draft on the inside of the boss should be $1/2^\circ$, with a 45° chamfer at the top of the boss. If a boss is to be attached to a primary wall, avoid thick regions, use gussets to structurally support the boss.¹

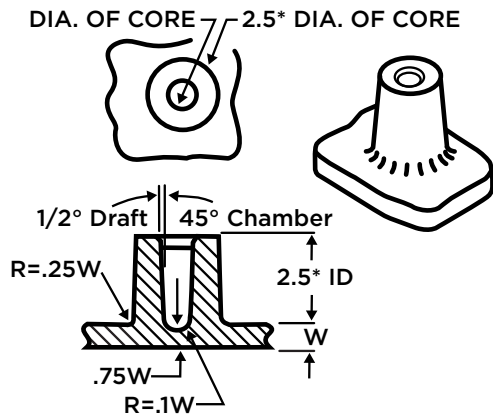

FIGURE 8 - Boss design guidelines

Gusset Design

Gussets are used to support a boss, because they do not cause thick side wall regions. Thick side walls will cause sink in the part, because the plastic will shrink away from the mold wall due to the increased heat in these areas. The following design guides should be followed when designing for gussets, and side wall bosses.

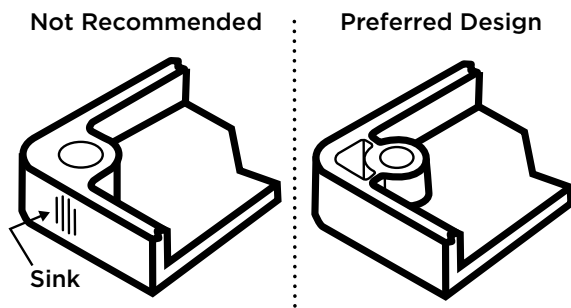

FIGURE 9 - Side wall boss design guidelines

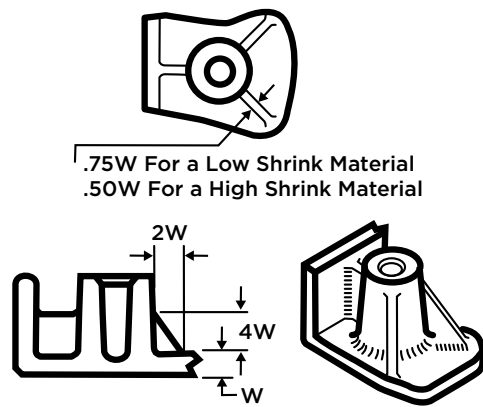

FIGURE 10 - Gusset design guidelines

STRUCTURAL HOLE DESIGN GUIDELINES

When placing holes in a part, they are either for structural support or cosmetic reasons. There are different guidelines to follow for each. For a structural support, each hole should be placed at least one diameter of the hole apart. They should be placed two times the diameter from the outside wall and one times the diameter from an inside wall. Figure 10 shows the proper design for structural holes.¹

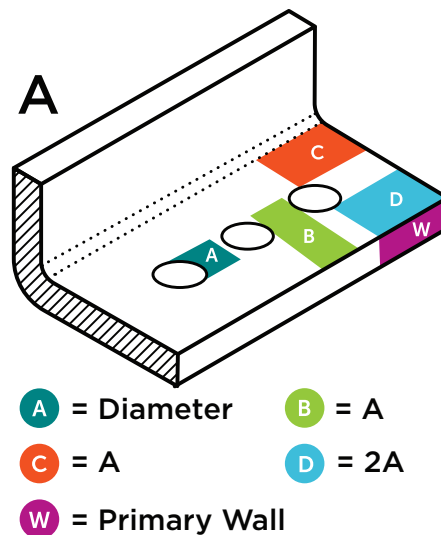

FIGURE 11 - Structural hole design guidelines

NON-STRUCTURAL HOLE DESIGN GUIDELINES

If the holes are not for structural design, they should all be placed two times the nominal wall thickness apart, and from an outside or inside wall. Figure 11 shows how to design a non-structural hole.

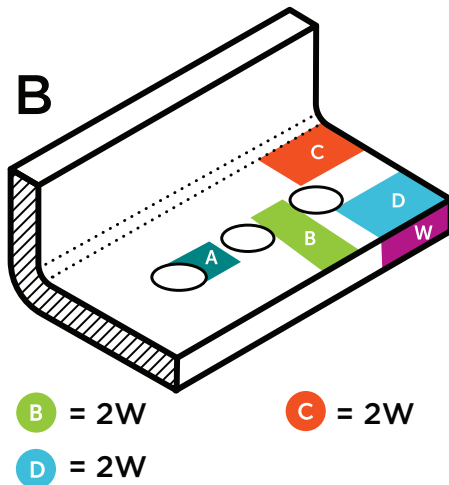

FIGURE 12 - Non-structural hole design guidelines

SNAP FITS

Snap fits can be used when mechanical fasteners cannot. Snap fits can be designed for almost any material; the equations from figures 12 and 13 can be used to calculate the correct design. The “ ϵ ” is the modulus of the specific material, “ L ” is the length of the snap fit, and “ t ” is the thickness of the snap fit. “ K ” is the proportionality constant, which can be determined from figure 13.

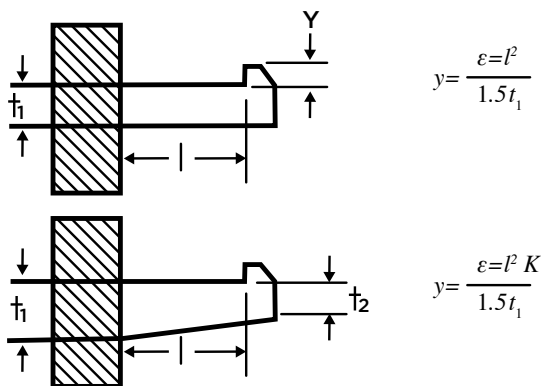

FIGURE 13 - Snap fit design guidelines

Snap fits are only recommended for certain gravities of Gravi-Tech. Highly loaded polymer systems can be brittle, which can lead to more breakages when using snap fits. Please contact your Avient account manager for more information.

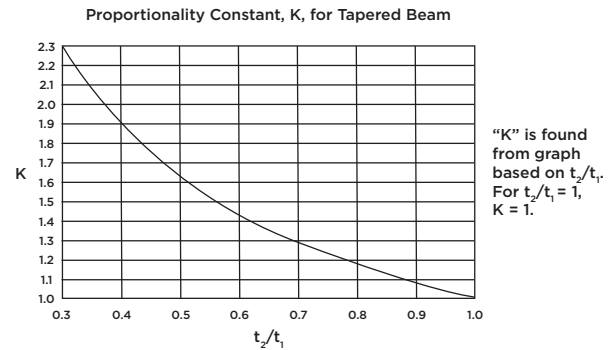

FIGURE 14 - “K” proportionality constant

PRESS FITS

Press fit design is determined by the hoop stress on the boss and the pull-out force needed. Hoop stress can be determined using the following equations (figures 15–18).¹

- V = Length of Boss (figure 14) = .400
- I = Interference Fit (figure 15)
- W = Geometry Factor (figure 16)
- H = Hoop Stress (figure 17)
- E = Material Modulus
- μ = Frictional force between materials
- L_{Engage} = length of engagement between the shaft and the hub

Press Fit Example Problem

Figure 14 is an example of a press fit problem. The equations listed in figures 15–18 will help determine the pull-out force on the press fit. The pull-out force will determine how difficult it will be to pull the two pieces apart.

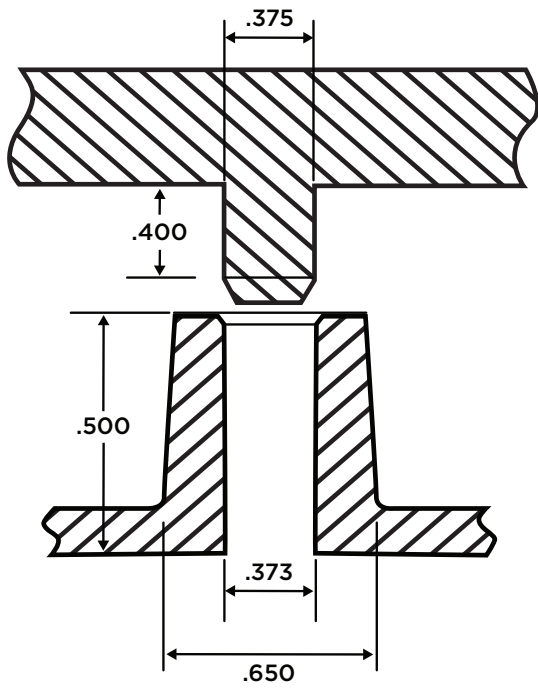

FIGURE 15 - Press fit example

$$I = D - 0.373 = 0.0002''$$

FIGURE 16 - Interference fit variable

$$W = \frac{1 + \left(\frac{D_{Shaft}}{OD_{Hub}}\right)^2}{1 - \left(\frac{D_{Shaft}}{OD_{Hub}}\right)^2} \quad W = \frac{1 + \left(\frac{0.375}{0.650}\right)^2}{1 - \left(\frac{0.375}{0.650}\right)^2} = 1.998$$

FIGURE 17 - Geometry factor variable

$$\sigma_H = \frac{I \times W}{D_{Shaft} \left(\frac{W + \nu}{E}\right)} \quad \sigma_H = \frac{0.002 \times 1.998}{0.375 \left(\frac{1.998 + 0.4}{450000}\right)} = 200psi$$

FIGURE 18 - Hoop stress equation

MECHANICAL FASTENERS

Figure 19 below, shows the proper way to design for mechanical fasteners.¹

$$F = \frac{\pi \times \mu \times D_{Shaft} \times l_{engage} \times \sigma_H}{W}$$

FIGURE 19 - Press fit pull-out force

Machine Screw & Bolt

Machine screws and bolts require many parts for assembly. It will need access to both top and bottom for assembly, and it needs locking hardware on bottom to avoid vibration and loosening. This is a durable assembly method, and acceptable for most plastics.

Machine Screw & Insert

This fastener option keeps one smooth surface obtained, with using fewer parts required for assembly. The insert must be threaded in after molding or molded-in, and also requires special tooling for the insert. This assembly method has good overall durability, and is suitable for repeated assembly.

Self-Threading Screw + Plastic Boss

This fastener method also keeps one smooth surface, and has the fewest parts required. This method has mating plastic threads formed during assembly. Unfortunately, this method only has limited durability and has a minimum amount of assembly repeatability.²

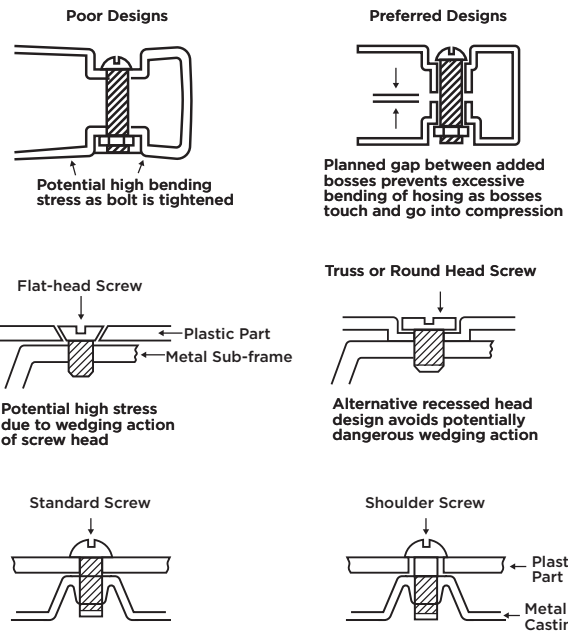

FIGURE 20 - Mechanical fasteners design guidelines

ADHESIVE TYPES

A chart containing the various specific adhesive types, with advantages and disadvantages of both can be seen in the appendix.

Solvent

Solvents soften surfaces of plastic (plastic must be soluble)—best for amorphous or low crystalline plastics, such as ABS, acrylic, cellulosic, PC, PS, PPO, and vinyls. This type of adhesive cannot be used for thermosets.

Body Adhesive

This adhesive is a solvent containing the parent resin of the parts to be bonded. Primary advantage over plain solvent is that it can be spread on without running.

Monomeric Cement

Cement made from monomer of parts to be assembled. Cement is catalyzed so bond is made by polymerization rather than solvent evaporation. Example: for two PMMA parts, MMA (PMMA monomer) acts as a solvent cement, then polymerizes.

Elastomeric Adhesive

This adhesive is rubber dissolved in solvents, and is very versatile. Example: caulking.

Reactive

Reactive materials are commonly made from, and are used to bond thermoset materials. Example: epoxy - 100% solids (no solvents). When polymerized, it hardens and there is very little shrinkage. This yields low stresses (vs. polyester and phenolic adhesives).

Hot Melt

Hot melt adhesives are 100% solids, and are used for light duty applications. Example: Glue guns

Cyanoacrylate

This type of adhesive is methyl/ethyl based esters and is formed using anionic polymerization. Cyanoacrylate is great for rapid one part processes, due to the various viscosities. This adhesive is not very chemically resistant, and has lower strength properties.

CHAPTER 4 | MOLD DESIGN GUIDELINES

COLD RUNNER LAYOUTS

Herringbone (Fishbone) Runner

This type of runner has an unbalanced fill, which can be artificially balanced by adjusting runner sizes. This usually still results in unbalanced filling and is not a recommended design.²

“H” Pattern Runner

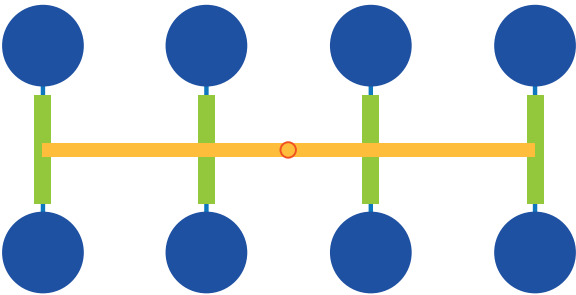

FIGURE 21 - Herringbone runner

This type of runner delivers a geometrically balanced type of fill, and is recommended for most multi-cavity tools. It is geometrically balanced because the flow length to each cavity is equal. It is limited to a number of cavities such as (4, 8, 16, 32, 64). Any cavitation above four, that exhibits unbalanced flow, is a candidate for melt rotation technology. Rotating the melt will solve the shear induced imbalance caused by the runner.²

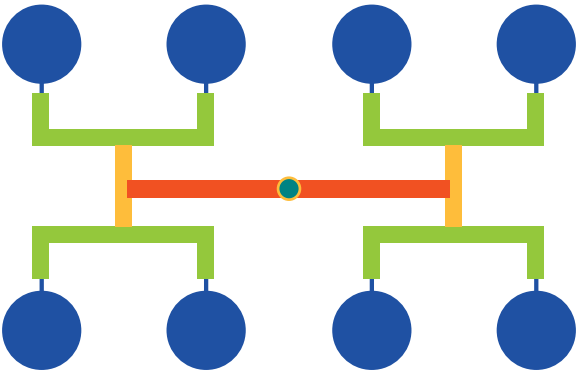

FIGURE 22 - “H” pattern runner

Radial Runner

This type of runner is used for small round parts and is also a geometrically balanced runner. One of the down sides of this type of runner is that it is difficult to machine.

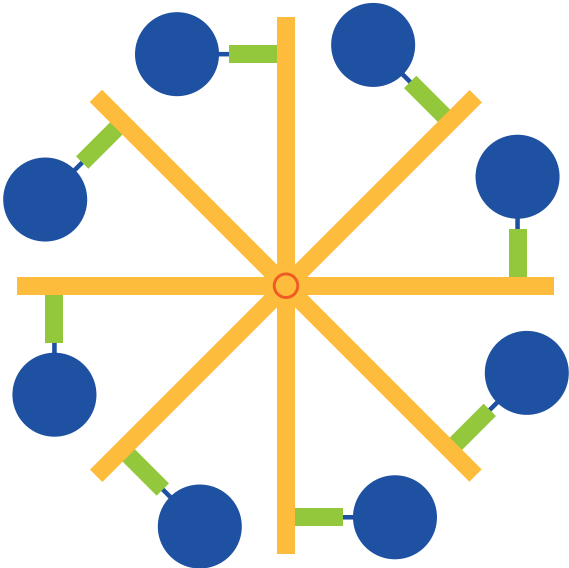

FIGURE 23 - Radial runner

RUNNER SIZING AND DESIGN

Runner Cross Sections

The best type of runner is the full round, because it has the lowest pressure drop from nozzle to cavity. Full round, trapezoidal, and modified trapezoidal are the only types of runners that should ever be used. Figure 24 shows the various runner cross sections.²

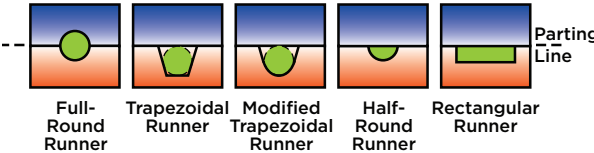

FIGURE 24 - Runner cross sections

Runner Sizing

Runners need to be large enough to allow for filling and packing phases. For most plastic materials, the runner size will be dependent upon the flow characteristics of the material. Gravi-Tech materials should have a minimum runner diameter of Ø0.125" (3.175 mm).

Runner Branching

When branching a runner it is important that the flow velocity and pressure drop remain constant throughout. The equation below should be used when branching runners. The diameter of the feed is the runner closer to the sprue, and the branch is the diameter further from the sprue. "N" is the total number of branches.

$$\text{Ø Feed} = \text{Ø Branch} * N^{1/3}$$

HOT RUNNER LAYOUTS

Hot runner systems have two types of heating situations, internally and externally heated. There are two main parts of the unit, the manifold and the nozzles or drops. The minimum hot runner diameter that can be used with Gravi-Tech is Ø0.125" (3.175 mm).

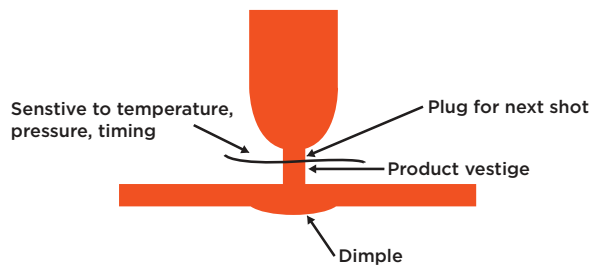

FIGURE 25 - Open gate hot runner

Open Gate

The gate in this type of hot runner stays open for the flow of plastic under pressure. It then freezes after pack and hold and acts as a plug.

Open Circular Gate

The material freezes in the plug section after pack and hold. The plug is then pushed into the cavity of the next shot, melted, and disappears among the rest of the melt flow.

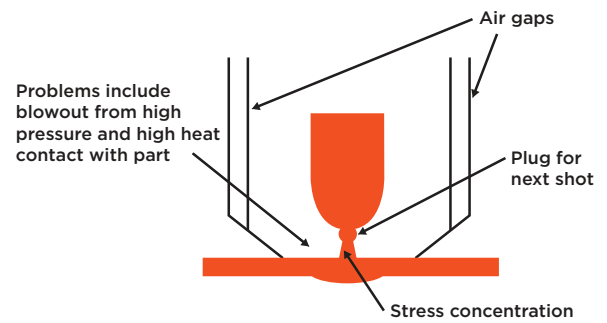

FIGURE 26 - Open circular gate hot runner

Open Annular Gate

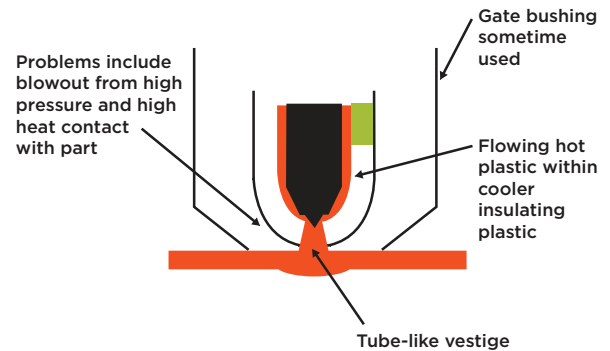

FIGURE 27 - Open annular gate hot runner

VALVE GATE

Single-acting gates open with injection pressure and close under spring/ air cylinder action. Double-acting gates can open and close using independently controlled air cylinders.

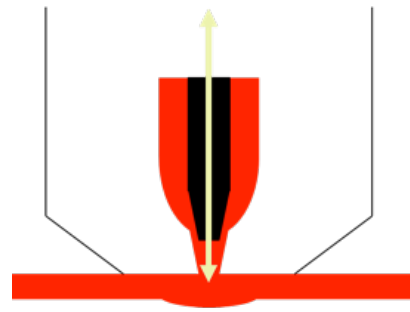

FIGURE 28 - Valve gate

GATE SIZING AND LOCATIONS

An open annular gate is an orifice through which a cavity is filled. Gates are designed to be as small as possible to keep the cosmetic effects minimal. However, a gate needs to be large enough to provide good packing. It does need to be the first section of the part to freeze.

Gate Sizing

Gate sizes for Gravi-Tech should be 60%–80% of the nominal wall thickness, with a minimum gate size recommendation of $\text{Ø}0.100$ ".

Gating Location

Choosing the correct gate location is an extremely important part of the mold design process. Gates need to be placed in areas that will provide balanced and unidirectional fill. A gate should be placed in a thick area, far from the thin wall sections; against a perpendicular wall to help prevent jetting and gate blush. Also, in a location that will prevent weld line. If weld lines cannot be prevented, place the gate in an area that will move the weld line to a non-cosmetic section of the part. Gates should be in areas that will avoid "picture-framing" or areas that could cause gas traps.

GATING TYPES – MANUAL TRIM GATES

These types of gates require manual trimming once the part is ejected from the mold. In most cases, a simple pair of shears can remove the gate. However, in some cases a robot can be used to automatically remove the gate. These types of gates are usually used when materials are shear sensitive, because the gates are larger and thus create less shear. The exceptions for this are the diaphragm gate and the ring gate.

Edge Gate

This is the most common manual trim gate. The typical width of this gate is 1–4 times the wall thickness. This type of gate can be a constant thickness or it can be tapered.

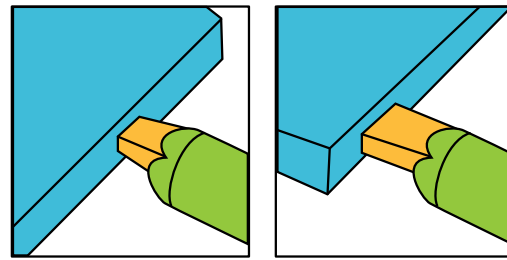

FIGURE 29 - Edge gate

Tab Gate

A tab gate is similar to an edge gate, however, the tab contains the shear stresses due to molding. The tab is used to lower the shear stress throughout the part, because most of the stress is controlled within the tab section.

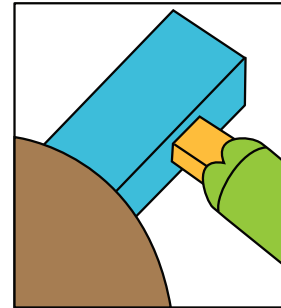

FIGURE 30 - Tab gate

Sprue Gate

The sprue is gated directly into the part. The gate size is then dependent upon the sprue orifice size.

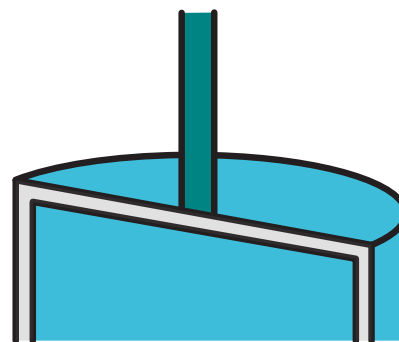

FIGURE 31 - Sprue gate

Fan Gate

This is basically a wide edge gate, and is used when it is difficult to develop a flow front when entering the part.

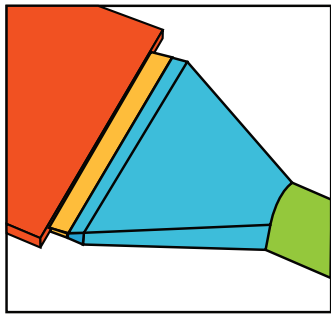

FIGURE 32 - Fan gate

GATING TYPES: AUTOMATIC DEGATING

Automatic degating is used for most small parts, due to the large volume being produced. This eliminates any secondary gate-cutting operations, because the mold steel is used to cut the gate from the part while it is ejecting.

Tunnel Gate

A tunnel gate is the most common automatic gate, and is a tapered gate that intersects the part below the parting line. The orifice diameter should be 25%-75% of the nominal wall thickness.

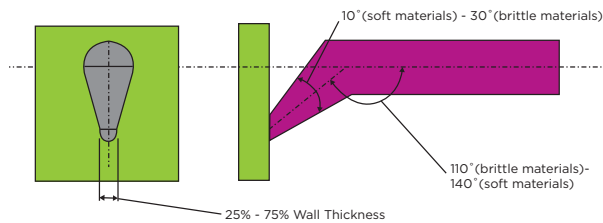

FIGURE 33 - Tunnel gate

COOLING LAYOUTS

There are two main types of cooling line layouts, series and parallel. Series is setup with only one circuit that the coolant can flow through. Parallel has multiple lines that the coolant can take. Baffles and bubblers can also be used to cool deeper cavities or cores. Baffles flow up and around a pipe structure that protrudes into the core, and bubblers flow up this pipe structure and then out and around it.²

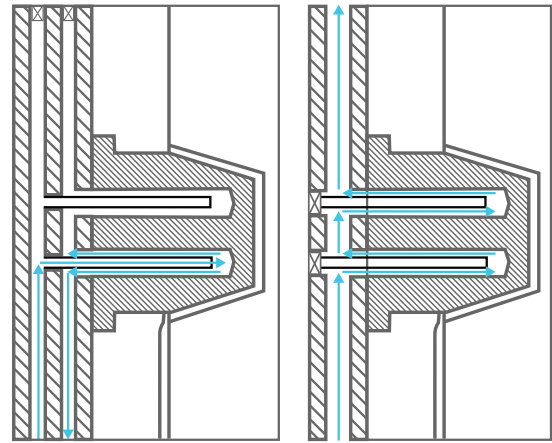

FIGURE 34 - Bubbler (left) & Baffle (right)

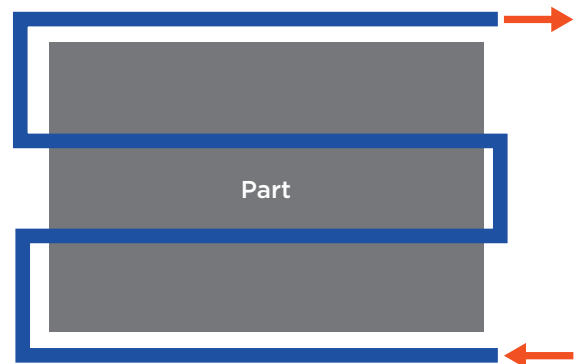

FIGURE 35 - Series cooling line layout

Series

This type of cooling layout uses the least amount of coolant, but it has the highest pressure drop. It also has the largest temperature differential, because all of the channels get the same coolant flow.

Parallel

This circuit provides the maximum amount of cooling possible because it has the lowest pressure drop and temperature differential. It also uses the most coolant, and the flow channels with the highest restrictions obviously get the least amount of cooling.

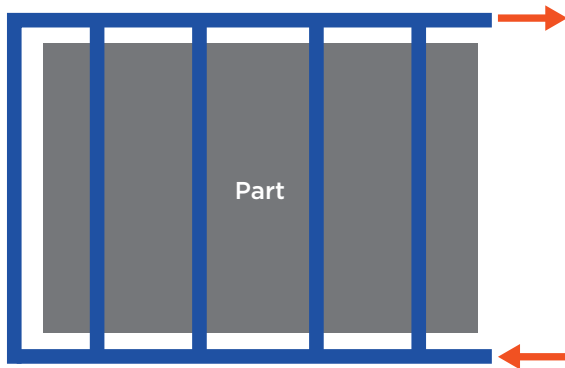

FIGURE 36 - Parallel cooling line layout

Cooling Line Guidelines

The rules for cooling line layouts are to keep the depth and pitch ratios constant throughout. All water lines should be a water line diameter away from other mold features such as ejector pin, core pins, or part geometry. The water line connections to the mold should be kept to as few as possible, and jumpers should be avoided unless permanent jumpers can be added.

| | SERIES | PARALLEL |
|----------------------------|------------|----------|
| Pressure Drop | High | Low |
| Flow Rates | Consistent | Variable |
| Temperature Rise Potential | Large | Small |
| Horsepower Requirements | Higher | Lower |
| Reynolds Numbers | Higher | Lower |

FIGURE 37 - Parallel vs series cooling line layout

EJECTION

A method of ejection is needed for all plastic parts, this is due to the shrinkage seen in plastic parts. The plastic will shrink onto the core side of the mold, which needs assistance to be ejected from the mold. Ejection needs to work around the cooling lines. Ejector pins should be put in places that require more ejection force. The layout should be balanced and even, and should position on non-cosmetic surfaces.² Balanced ejection is critical for Gravi-Tech filled resins.

Do not allow finished parts to fall into a bin without protection. A conveyor or padded bin will prevent part damage following ejection from the mold.

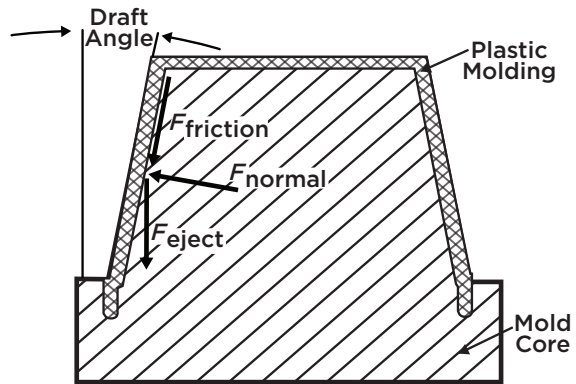

FIGURE 38 - Friction force

Ejector Pin Layout

An ejector pin layout should be uniform across the entire part, and when possible pins should be placed on vertical surfaces such as ribs, corners, or intersections. Larger pins can be placed at these locations, which is depicted in figure 39.

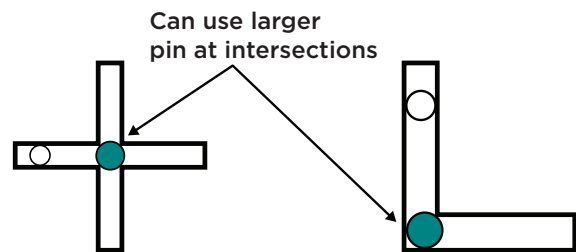

FIGURE 39 - Ejection pin layout

Ejector Blades

Ejector blades are used for long rib sections of the part. These blades are difficult to machine and are easily bent or broken.

Ejector Sleeves

An ejector sleeve is a hollow pin that slides along a core pin, which delivers a larger contact area. These deliver an even push on the pins and cores. Unfortunately, ejector sleeves do not facilitate cooling inside of a pin.

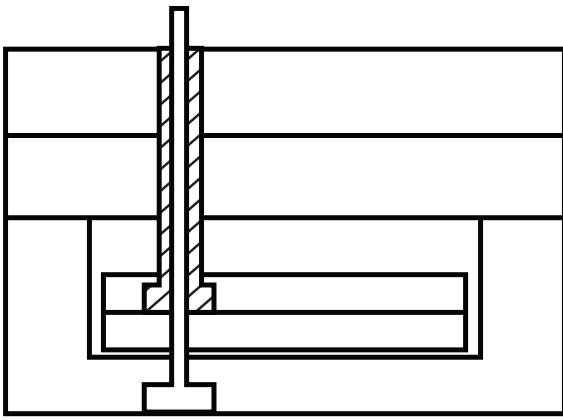

FIGURE 40 - Ejector sleeve

Stripper Plate

This type of ejector is often used with round parts to provide a constant ejection force on the entire part. Figure 41 shows how the stripper plate works.

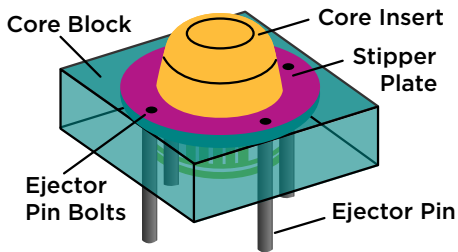

FIGURE 41 - Stripper plate

Ejector Pin Design Guidelines

When designing ejector pins, the following guidelines should be used, which can be seen in figure 42.

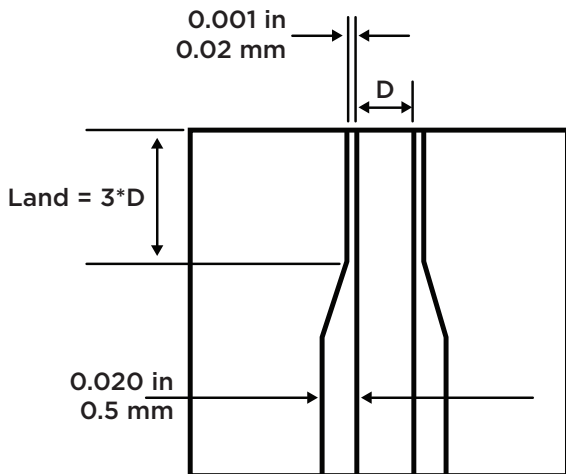

FIGURE 42 - Ejector pin design guidelines

VENTING

Air inside of the cavity must be allowed to escape, so that the plastic can fill the entire cavity. Without venting, burning and no-fill areas can occur. The vent is the clearance between two surfaces through which air can escape. The vent land is the distance air travels through the vent. The vent groove is the air collector close to the cavity space which the vents lead.

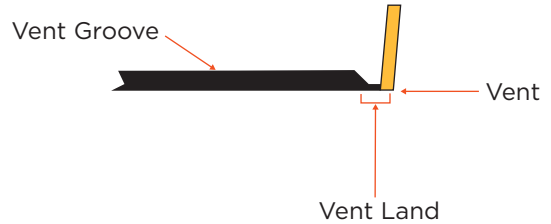

FIGURE 43 - Venting areas

Venting Guidelines

The vent should be made as large as possible, which is dictated by the material. Place the vents at the end of fill or where the flow paths combine. The vent should be 0.125" (3.175 mm) minimum, which widens out into the groove section, as seen in figure 44.

Venting Guidelines by Resin

- PC: .001"–.002" depth & .250" width
- PC/PSU: .002"–.003" depth & .250" width
- PES: .003"–.004" depth & .250" width
- PEI: .001"–.003" depth & .250" width
- PP: .001"–.002" depth & .250" width
- ABS: .0015"–.0025" depth & .250" width
- PEEK: .002"–.004" depth & .250" width

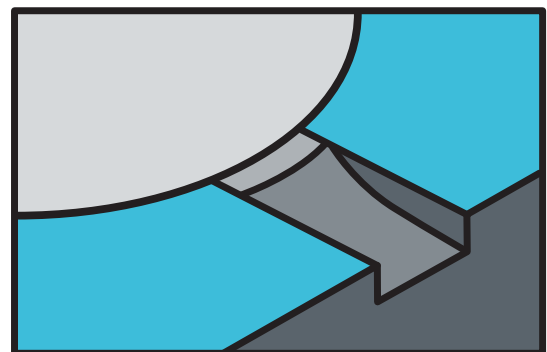

FIGURE 44 - Venting guidelines

CHAPTER 5 | PROCESS OPTIMIZATION

Process optimization ensures a quality process and minimizes cycle time.

MACHINE SIZING

Shot Capacity & Barrel Sizing

The size of the barrel needs to be large enough to ensure proper melting and mixing of the material, at the desired shot size. The shot size of the machine needs to be large enough to fill the part completely and allow for a cushion. However, the residence time of the material needs to be reduced as much as possible to avoid any degradation. The residence time of any material should strive to be less than five minutes, and certainly not longer than ten minutes. Typical shot sizes need to be between 30%–80% of barrel capacity.

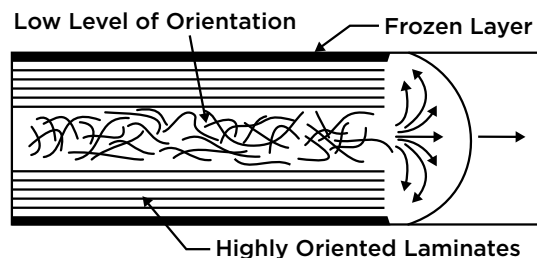

FIGURE 45 - Non-Newtonian fluid flow

FOUR MAIN PLASTIC VARIABLES

Flow Rate

Plastics are a non-Newtonian fluid, therefore, with a higher shear rate, the viscosity of the material is reduced. The relative shear rate is determined by the fill time. Shear rate and relative viscosity can be calculated by the equations below. A faster flow rate will decrease the thickness of the frozen layer. Relative viscosity and shear rate can be calculated using the equations below.³

$$\text{Relative Viscosity} = \text{Transfer Position} * \text{Fill Time}$$

$$\text{Shear Rate} = \frac{1}{\text{Fill time}}$$

Fountain Flow

Plastic materials exhibit fountain flow due to the high viscosities and high aspect ratios. The plastic molecules in the middle of the flow channel mostly remain in an amorphous arrangement with a low level of orientation. The molecules at the mold wall freeze instantly and is referred to as the frozen layer. The layer of plastic just inside of the frozen layer sees the highest shear rates.

Temperature

The hotter the material is, the easier it will flow. This is due to the polymer chains being spaced further apart, and making it easier for them to slide past one another.

Pressure Gradient

Plastics are compressible, and need to be packed into the mold. This reduces shrinkage and voids. There is a pressure drop across the cavity at the transfer pressure. This is due to the machine transferring from injection speed controlled to pressure controlled. This pressure control is what helps fill and pack material into the mold.

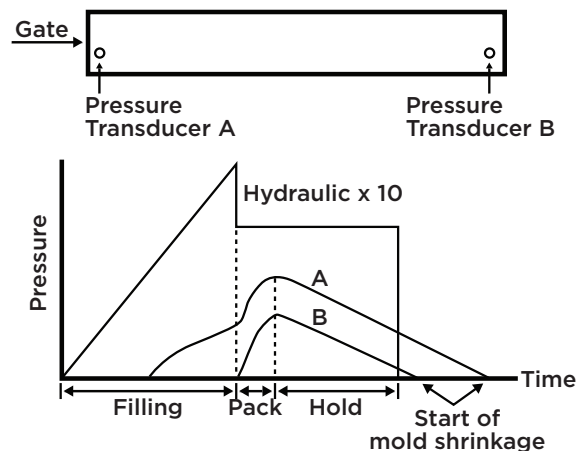

FIGURE 46 - Pressure vs. Time Graph

Cooling Rate & Time

Cooling a part quickly will freeze in the polymer chain orientation. Semi-crystalline material will not have time to form many crystals and thus be clearer. Cooling quickly will reduce the amount of shrinkage in the part, and will lock in the polymer chain stresses as well. This will

result in stronger parts due to the locked in stresses. Longer cooling times will result in more dimensionally stable parts and less warpage. The cooling rate is determined by the material, part design, and desired cycle time.

ESTABLISHING A PROCESS – THE SCIENTIFIC MOLDING METHOD

The scientific method of molding is a way of creating the largest processing window for the mold and material. A larger processing window will account for the lot to lot changes between materials, without having to make process changes.³

Setting the Beginning Variables

- Injection Pressure = Maximum of machine
 - Should not be pressure limited
- Injection Velocity = Maximum of machine
 - This is for the injection velocity curve starting point
 - If flashing is an issue start slower and then increase
- Injection Cut-Off Time = 15 seconds
 - This is only a limiting factor, needs to be above 10 seconds for velocity graph
- Hold Pressure = 0
 - Need to get 95% full part with a hold pressure of 0
- Hold Time = 10-15 seconds
 - Need to ensure gate is frozen
- Screw Speed = 90% of Maximum
 - Unless shear sensitive material, if shear sensitive, set RPMs to optimum
- Cooling Time = 10–15 seconds
- Shot Size = 50% of calculated part volume
- Decompression = .25in
- Transfer Position = High enough to ensure a cushion
 - Cushion size does not matter but there must be a cushion to keep a constant pressure on the melt during hold time
 - Typically 0.25" is sufficient

- Back Pressure = 800-1000 plastic pressure
 - 100–150 hydraulic pressure
 - Unless specified by material data sheet

Determining Shot Size

The shot size should be determined by calculating the combined volume of the parts and the runner system. If the runner system is a hot runner, then only the combined volume of the parts is needed. Get a 95% full part of the fullest part in a multi-cavity mold. If flashing is a major concern, start with a slower injection speed, then gradually increase, while decreasing shot size, until a 95% full part is reached at maximum injection velocity.

Optimizing Injection Velocity

The objective of this step is to find where the injection velocity will fill out the part completely, and not pressure limit the machine. It is better to fill out the part at slower speeds in-order to let any compressed air escape, and to get the best surface finish on the part.³

- Using all of the previous settings, record the Transfer Pressure, Fill Time, and Injection speed
- Reduce the injection velocity by 10% and record the same values

| Transfer Pressure (psi) | Fill Time (sec) | Injection Velocity (in/sec) | Relative Shear Rate | Relative Viscosity |
|-------------------------|-----------------|-----------------------------|---------------------|--------------------|
| 1238 | 0.20 | 8.00 | 5.00 | 247.60 |
| 1125 | 0.22 | 7.00 | 4.55 | 247.50 |
| 1058 | 0.25 | 6.00 | 4.00 | 264.50 |
| 960 | 0.35 | 5.00 | 2.86 | 336.12 |
| 870 | 0.45 | 4.00 | 2.22 | 391.65 |
| 780 | 0.58 | 3.00 | 1.72 | 452.59 |
| 690 | 0.85 | 2.00 | 1.18 | 586.78 |
| 600 | 1.35 | 1.00 | 0.74 | 810.45 |
| 510 | 2.50 | 0.75 | 0.40 | 1275.83 |
| 420 | 5.23 | 0.50 | 0.19 | 2198.34 |
| 330 | 9.56 | 0.25 | 0.10 | 3157.99 |
| 240 | 15.26 | 0.10 | 0.07 | 3667.49 |

FIGURE 47 - Injection Speed

- Keep reducing the injection velocity until a fill time of 10-15 seconds is reached
- Calculate the Relative Viscosity for each of the Injection Speeds using the equation above (Transfer Pressure * Fill Time)
- Calculate the Relative Shear Rate for each of the injection speeds using the equation (1/Fill Time)
- Plot the points on a graph and find the optimum velocity
- The optimum velocity will be where the curve starts to level out

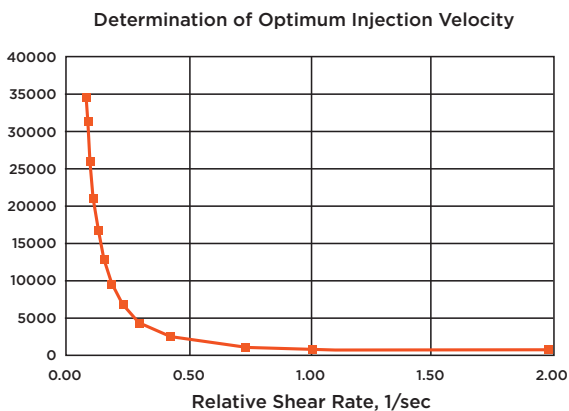

FIGURE 48 - Viscosity vs Shear Rate Curve

In figure 48 above, the optimum velocity is where the plotted line crosses the black trend line; therefore the optimum velocity would be about 1.00 in/sec.

Optimizing Hold Pressure

The goal of hold/pack pressure is to pressurize the cavity to hold the plastic against the mold walls long enough for it to freeze, and maintain dimensional stability.

- Use the optimum velocity from the previous step and once again, fill the part to 95% full
- Add just enough hold pressure to fill out the part, until it is just full
 - There should be sinks in the part; it should not look like a final part
- Increase the hold pressure until the part slightly flashes, around the parting line of the part

- Once these two values have been found, take the average of them, and this is the hold pressure to be used when processing
 - If sinks are found in the part at the new hold pressure, increase it until the sinks disappear or flashing occurs. If the part begins to flash and there are still sinks, the problem is most likely not insufficient hold pressure, but rather could be material related

Gate Freeze Study

The gate freeze study is performed to conclude at what time the gate freezes. The goal of the gate freeze is to ensure the packed material stays in the cavity. If the gate is not frozen and the pressure is removed, the plastic can “back-flow” into the runner. In relation, if the hold/pack time is too long, the runner will be packed out, which could cause processing problems.

- The gate freeze study will be performed by decreasing the hold time and increasing the cooling time
- Always start at a higher hold time to be certain the gate will be frozen at the starting point
- Weigh only the parts and plot the points on a graph
- Once the weight of the part starts to level off and has no dramatic change, then the gate is frozen
- If the gate freeze time is between 1–6 seconds, then the designated hold time should be 1 second higher than the gate freeze time
 - ex. Gate Freeze Time = 4 seconds, 4+1 = 5, Hold Time = 5 seconds
- Figure 45 shows an example of the gate freeze study. The gate freeze time is 6 seconds, therefore the ideal hold time is 7–8 seconds

Cooling and Recovery Time

Two variables will dictate the cooling time of a part: screw recovery time and material cooling time.

- The material has to be cool enough before ejection so that the ejector pins do not produce a surface defect on the part
 - i.e. Ejector pins may push into the part, or may warp and deflect the part
- The screw recovery is dictated by how shear-sensitive the material is; if the material is not shear-sensitive the screw recovery RPMs should be set at 90% of maximum. If the material is shear-sensitive, consult the material data sheet or processing guide for instructions to set recovery time
- The cooling time should only be 1–2 seconds longer than the screw recovery time, unless dictated by dimensional stability or part thickness

Minimize Clamp Pressure

This step is done to reduce the amount of energy used by the machine.

- Reduce the clamp tonnage until flash is seen around the parting line, then increase the clamp tonnage by 5-10%

Minimize Cycle Time

- Mold Open/Close – Should be as fast as possible, without slamming, and still produce a nice fluid motion
- Ejector Speed – As fast as possible, without influencing part quality
- Ejector Stroke – Only stroke the ejectors as many times as needed to separate the part from the core
 - i.e. Do not have the ejectors stroke 5 times if the part falls off the core on the second stroke
- Cushion – The cushion should be set to be 10% of the shot size
 - This can be increased or decreased by changing the shot size and transfer position by the same amount
 - i.e. Shot Size = 1.00 & Transfer Position = .50, Increase both by .10 to set a cushion of .10. Shot Size = 1.00 + .10 = 1.10, Transfer Position = .50 + .10 = .60

Set Safeties

This step is to ensure the machine will alarm and alert nearby employees if the machine malfunctions, or if a part gets stuck.

- Injection Fill Time – Should be 10% above the actual fill time
- Injection Pressure – Should be 200 psi hydraulic pressure, or 2000 psi plastic pressure higher than actual
- Recovery Timer – Should be 1–2 seconds above actual recovery time
- Cycle Time – Should be 2–3 seconds above actual cycle time

PROCESS DISTINCTIONS

When processing Gravi-Tech materials, the “hot and fast” approach is used most often. This is done to ensure the material will not freeze off during the injection cycle.

Injection Speed

The injection speed for Gravi-Tech material is most often higher than what is used for other formulations. Because this material has such a high heat transfer rate, it tends to freeze off quickly. Due to this increased heat transfer rate, a faster injection speed should be used to increase the shear heat in the material during injection.

Melt Temperature

The viscosity of Gravi-Tech materials is higher than with NEAT resins due to the amount of filler content. A higher melt temperature will lower the viscosity, allowing the material to flow farther before freezing. The proper temperature profile can be seen in Chapter 2.

Gates

Many different types of gates can be used, such as edge, tab, fan and large tunnel gates. Gate type should be selected based on location and part geometry.

Gate diameters should be no less than 2.54 mm (0.100"). Land lengths of 0.50mm–0.90mm (0.020"–0.035") are typically recommended.

Runners

Full-round runners or a modified trapezoid runner are ideal for Gravi-Tech materials. Half-round runners are not recommended.

Only naturally balanced runner systems ("H" patterns) are recommended.

Runner diameters should be no less than 3.175mm (0.125").

Step each 90° bend in the system down in size (from sprue to gate) approximately 1.5mm (1/16") to reduce pressure drop.

Place vents at each 90° intersection and vent to atmosphere.

Hot runner molds are acceptable and should be sized by the manufacturer.

Cold Slug Wells

Place these wells at the base of the sprue to capture the cold material first emerging from the nozzle. Place wells at each 90° bend in the runner system.

Well depths approximately 1.5 times the diameter of the runner provide the best results.

CHAPTER 6 | TROUBLESHOOTING

FOUR MAIN AREAS

Check all of these areas before changing anything in the process.⁴

Mold

- Cooling channel obstructed
- Vent plugged
- Core bent
- Damaged tooling
- Runner shutoff partially closed
- Part stuck
- Gate plugged
- Tooling shifted

Machine or Equipment

- Thermolator unplugged
- Variac unplugged
- Material bridging
- Drying turned off

Material

- Contamination
- Lot change
- Poor mixing
- Material dust
- Material not dried

Process

- Changes
 - Documented
 - Undocumented

OBTAIN INFORMATION

Obtain as much information as possible about the defect

- Ask operators
 - When did it start occurring
 - Is it on every part

- Set-Up Tech
 - Is this how the process started up
 - Has this happened before

STRATEGY THEORY

Part Consistency

- Does the defect happen randomly or every part

Machine Cycle

- Is it consistent
- Injection pressure limited
- Screw hesitation

Check Settings

- What changed
- Did a heater band turn off
- Are valves sticking

Determine at which point in the process the defect occurs

- Injection
- Hold time
- Gate frozen
- Ejection
- Part deforming due to ejection
- Do a short shot progression

Change ONE setting at a time, and allow time for adjustment to affect the defect

- Change speeds and pressures first
 - Take immediate effect and easily reversed
- Change temperatures last
 - Take time to settle in
- Extreme Measures
 - Put mold into different press

DEFECTS

Angel Hair

- Commonly occurs on sprues and hot runner gates
- Long, thin strands of plastic material, which can tangle and cause components to stick together
- Can cause ejection problems

Root cause: Gate or sprue is not frozen and draws molten material with the sprue/part during mold open phase.

| SOURCES | | | |
|--|---|--|---|
| Mold | Machine | Material | Process |
| Damages or worn gate/sprue | Temperature settings overriding or changed Sprue breaks too soon | Contamination Lower viscosity lot Wet material | Nozzle too hot Cooling time too low Not enough decompression |
| RECOMMENDED ADJUSTMENTS | | | |
| Reduce gate size Increase cooling in gate areas Check gate for blockages | Install a shorter nozzle or specialty nozzle Ensure nozzle is temperature controlled | Dry material | Add screw decompression Increase hold pressure Increase hold time Increase cooling time Reduce nozzle tip temperature |

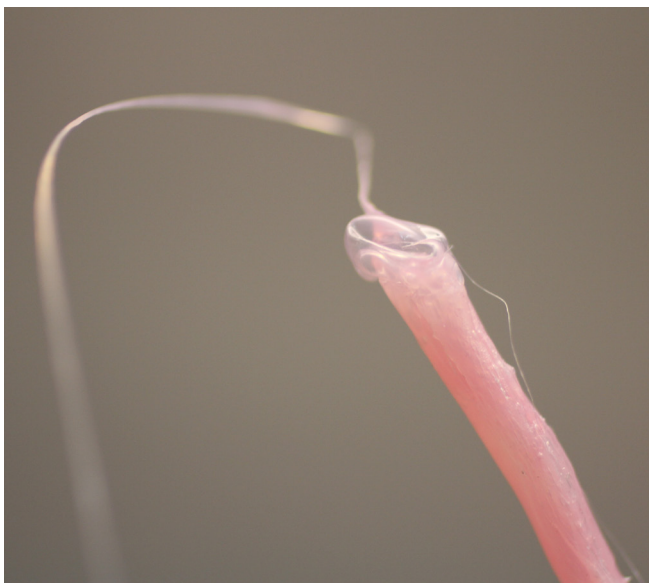

Blush

Root cause: Injecting too quickly through the gate.

| SOURCES | | | |
|--|---|-----------------------------------|---|
| Mold | Machine | Material | Process |
| Design of gate too small or in wrong location Insufficient venting | Machine not providing requested velocity Thermocouple pinched Heater overriding | Wet material Viscosity too low | Injection velocity too high Melt temperature too high or low Mold too cold |
| RECOMMENDED ADJUSTMENTS | | | |
| Increase gate size Remove sharp corners from gate detail Change gate type Change gate location Insure proper venting | | Dry material | Reduce injection velocity Increase melt temperature Decrease melt temperature Increase mold temperature Reduce mold temperature |

DEFECTS

Burns

Root cause: Dieseling of trapped gas or material degradation through heat or shear.

| SOURCES | | | |
|-------------------------------|--|---------------|----------------------------|
| Mold | Machine | Material | Process |
| Hot runner system | Screw configuration | Contamination | Injection speed too fast |
| Gate design | Heater malfunction | Wet material | Residence time too high |
| | Machine not providing requested velocity | | Too much decompression |
| RECOMMENDED ADJUSTMENTS | | | |
| Insure proper venting | Reduce clamp force | Dry material | Reduce compression |
| Change flow pattern | | | Reduce melt temperature |
| Change gate location | | | Reduce injection speed |
| Add venting to core pins | | | Increase transfer position |
| Add ejector pins to gas traps | | | |



Delamination

Root cause: Either contamination or extremely high degree of orientation.

| SOURCES | | | |
|--|--|---|--|
| Mold | Machine | Material | Process |
| Mold too hot | Wrong screw configuration | Contamination Wet material | Injection speed too fast Melt temperature too low Residence time too low Back pressure too low |
| RECOMMENDED ADJUSTMENTS | | | |
| Clean mold surface Stop using mold spray Check mold for condensation | Make sure material is thoroughly mixed | Dry material Check for contamination | Reduce injection speed Increase melt temperature Increase mold temperature Increase injection speed |

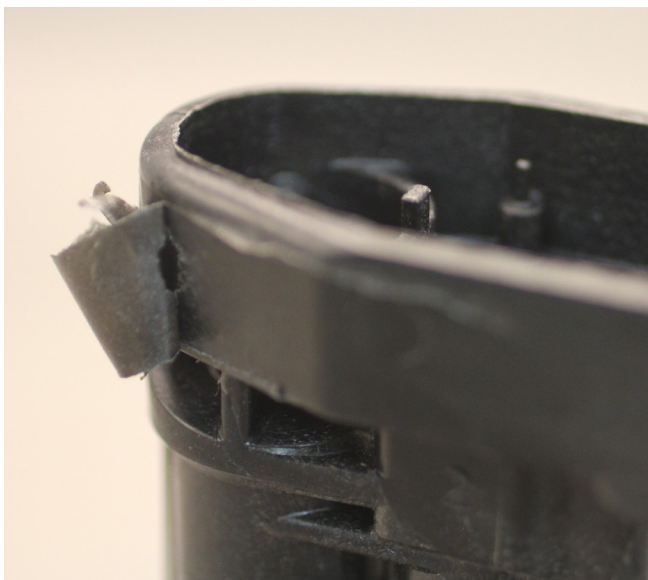

DEFECTS

Dimension—Small

- A DOE should be run to conclude which processing parameters have the greatest influence on part size

| SOURCES | | | |
|--|--|---------------------|---|
| Mold | Machine | Material | Process |
| Mold temperature too high Venting plugged | Cycle too short Check ring slippage | New lot of material | Under-packing |
| RECOMMENDED ADJUSTMENTS | | | |
| Increase gate size Check for proper venting | | | Increase pack pressure Increase hold time Increase melt temperature Reduce mold temperature Reduce transfer position Increase cooling time |

Dimension—Large

- A DOE should be run to conclude which processing parameters have the greatest influence on part size

| SOURCES | | | |
|---|-------------------------|--------------------------------------|--|
| Mold | Machine | Material | Process |
| Mold temperature too cold Hot runner too hot | Running out of material | New lot of material Contamination | Over-packing |
| RECOMMENDED ADJUSTMENTS | | | |
| Increase gate size Check for proper venting | | | Reduce hold pressure Reduce melt temperature Reduce hold time Increase mold temperature Increase transfer position |

DEFECTS

Distortion/Deformation

Root cause: Various causes—parts too hot to eject/packing/poor ejection design/tooling damage/high polish.

SOURCES

| Mold | Machine | Material | Process |
|----------------------|-------------------------|---------------|------------------------------|
| Tooling damage | Running out of material | Contamination | Melt temperature too high |
| Rolled parting lines | Barrel malfunction | Wet material | Over- or under-packed |
| Bent cores | | | Cooling time too high or low |
| Plating worn off | | | Injection speed too high |
| Mold too cold | | | Excessive back pressure |
| Broken ejector pin | | | |

RECOMMENDED ADJUSTMENTS

| | | | |
|--------------------------|------------------------------|--------------|------------------------------------|
| Reduce ejection velocity | Check for heaters overriding | Dry material | Increase/decrease hold pressure |
| Check for mold damage | | | Reduce hold time |
| Use mold release | | | Increase/decrease mold temperature |
| Reduce mold finish | | | Reduce injection speed |
| | | | Reduce back pressure |

Flash

- Excess material commonly found at parting lines or mold features

Root cause: Too much plastic or mold damage.

| SOURCES | | | |
|---|---|-------------------------------|--|
| Mold | Machine | Material | Process |
| Mold damages | Loss of clamp force Barrel malfunction | Contamination Wet material | Melt temperature too high Injection speed too high Transfer position too low Excessive pack pressure Excessive back pressure |
| RECOMMENDED ADJUSTMENTS | | | |
| Repair mold damage Clean parting line Reduce pinch-off land | Increase clamp force | Dry material | Reduce melt temperature Reduce mold temperature Reduce injection speed Reduce hold pressure Increase transfer position |



DEFECTS

Jetting

Root cause: Injection speed is too high for the viscosity of the material

| SOURCES | | | |
|---|---|---------------------------------------|---|
| Mold | Machine | Material | Process |
| Design of gate too small or in wrong location | Machine not providing requested velocity Heater overriding | Wet material Viscosity too low | Injection velocity too high Melt temperature too high Mold too cold |
| RECOMMENDED ADJUSTMENTS | | | |
| Increase gate size Remove sharp corners from gate detail Change gate type Move gate to a position where the melt stream will impinge upon a mold feature | | Dry material | Reduce injection velocity Increase melt temperature |

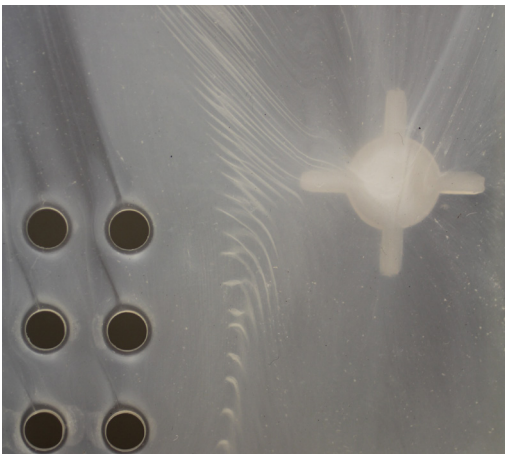

Plate-Out

- Build-up or deposit on mold surface

Root cause: One component of the material is not totally compatible.

| SOURCES | | | |
|--|--|--|--|
| Mold | Machine | Material | Process |
| Finish too rough Venting impaired | Screw configuration Overworking material | Non-compatible additive | Melt temperature too high Back pressure too high Injection speed too fast Mold too cold |
| RECOMMENDED ADJUSTMENTS | | | |
| Remove sharp corners from gate detail Insure proper venting Increase gate size | Use smaller screw/barrel Check melt uniformity Check L/D ratio | Dry material Check additive compatibility | Reduce melt temperature Reduce screw speed Reduce back pressure Reduce residence time Reduce injection speed |

DEFECTS

Short Shot

- Not enough material is being injected into the mold to fill out all of the cavities

Root cause: Not enough plastic is getting into the cavity.

SOURCES

| Mold | Machine | Material | Process |
|---------------------------|------------------------|------------------|----------------------------|
| Venting impaired | Screw problems | New lot | Under-packing |
| Shut-off partially turned | Barrel heater problems | Contamination | Injection speed too low |
| | | Material too dry | Not enough pack pressure |
| | | | Melt temperature too low |
| | | | Transfer position too high |

RECOMMENDED ADJUSTMENTS

| | | | |
|--------------------------------------|---|---|----------------------------|
| Make sure gate is not blocked | Insure cushion position | Make sure material was dried at proper settings | Increase melt temperature |
| Insure runner shut-off is not turned | Make sure screw is transferring at a correct position | | Increase mold temperature |
| Check venting | Change screw/barrel | | Increase injection speed |
| Increase gate size | | | Decrease transfer position |
| Change gating location | | | |
| Add flow leader | | | |



Sink

Root cause: Material is shrinking away from mold surface.

| SOURCES | | | |
|-------------------------|------------------------------|---------------------|---------------------------|
| Mold | Machine | Material | Process |
| Hot spots | Leaking check ring | Contamination | No cushion |
| Improper cooling | Barrel too hot | Too hot | Hold pressure too low |
| Venting plugged | | | Melt temperature too high |
| | | | Reduced transfer position |
| | | | Back pressure too low |
| RECOMMENDED ADJUSTMENTS | | | |
| Check venting | Insure cushion position | Add a foaming agent | Increase hold pressure |
| Add a flow leader | Insure proper screw recovery | | Increase hold time |
| | | | Reduce injection speed |
| | | | Reduce melt temperature |
| | | | Reduce mold temperature |
| | | | Increase mold temperature |



DEFECTS

Splay

- Silver streaks on part

Root cause: Material degradation

| SOURCES | | | |
|-------------------------------------|---------------------------------------|------------------------------|---------------------------|
| Mold | Machine | Material | Process |
| Venting impaired | Heater band overriding | Wet material | Injection speed too fast |
| Condensation | Wrong screw configuration | Contamination | Residence time too long |
| | | | Excessive decompression |
| RECOMMENDED ADJUSTMENTS | | | |
| Increase gate size | Check for condensation in feed throat | Check dry material dew point | Increase mold temperature |
| Check mold surface for condensation | | Dry material | Reduce melt temperature |
| | | | Reduce back pressure |
| | | | Reduce screw speed |
| | | | Reduce decompression |



Surface Finish

Root cause: Material is not reproducing the mold surface finish.

| SOURCES | | | |
|---|---|--------------------------|---|
| Mold | Machine | Material | Process |
| Venting impaired | Leaking check ring Heating band burned out | New lot Contamination | Melt temperature too low Hold pressure too low Back pressure too low Transfer position too high Injection speed too low |
| RECOMMENDED ADJUSTMENTS | | | |
| Clean mold surface Check vents Increase gate size | | | Increase melt temperature Increase mold temperature Increase hold pressure Increase hold time Increase injection speed Increase back pressure Decrease transfer |

DEFECTS

Gate Vestige

Root cause: Material doesn't have a clean break at gate.

| SOURCES | | | |
|--|--|-------------------------------|--|
| Mold | Machine | Material | Process |
| Tooling damage | Heater band overriding Leaking check ring | Contamination Wet material | Melt temperature too high Back pressure too high No cushion Pack pressure too high Hold time too low |
| RECOMMENDED ADJUSTMENTS | | | |
| Reduce gate size Increase cooling in gate area Check gate for blockage | Check thermocouples for continuity Ensure cushion is maintained | Dry material | Reduce melt temperature Increase hold pressure Increase hold time Reduce back pressure Increase cooling time Reduce tip temperature |



Voids

- Usually occurs in a thick section where the melt remains hotter than the rest of the part. Very difficult to resolve through processing

Root cause: Nominal wall thickness is not maintained or uneven cooling.

| SOURCES | | | |
|--------------------------|---|---------------|------------------------------------|
| Mold | Machine | Material | Process |
| Hot spots | Heater band overriding | Contamination | No cushion |
| Improper cooling | Leaking check ring | New lot | Hold pressure too low |
| Impaired venting | | | Melt temperature too high |
| | | | Reduce transfer position |
| | | | Back pressure too low |
| RECOMMENDED ADJUSTMENTS | | | |
| Check gate for blockages | Ensure cushion is maintained | Dry material | Increase/decrease melt temperature |
| Check runner shutoffs | Make sure screw is transferring at correct position | | Increase mold temperature |
| Increase gate size | | | Reduce injection speed |
| Add a flow leader | | | Increase hold pressure |
| | | | Increase hold time |

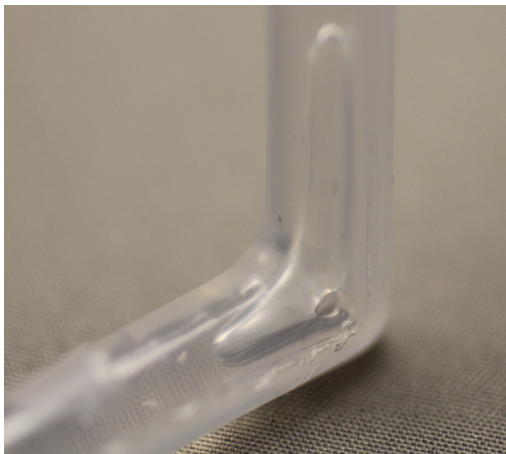

DEFECTS

Warpage

- Parts will warp to the hotter half of the mold

Root cause: Internal stresses caused by uneven shrinkage.

Note: Once the process has been established, the parts should be tested for dimensional stability over the range of service temperatures.

SOURCES

| Mold | Machine | Material | Process |
|------------------------------------|--|----------|---|
| Uneven cooling Damaged ejection | Heater band overriding Leaking check ring | New lot | Melt temperature too high Injection speed too high Cooling time too low Hold pressure too high Hold time too low Back pressure too high Transfer too high |

RECOMMENDED ADJUSTMENTS

| | | | |
|---|--|--|--|
| Plate with lower friction coating Maintain constant wall thickness Maintain constant cooling Reduce sharp corners Gate from thick to thin | | | Increase/decrease cooling time Reduce mold temperature Reduce melt temperature Reduce back pressure |
|---|--|--|--|

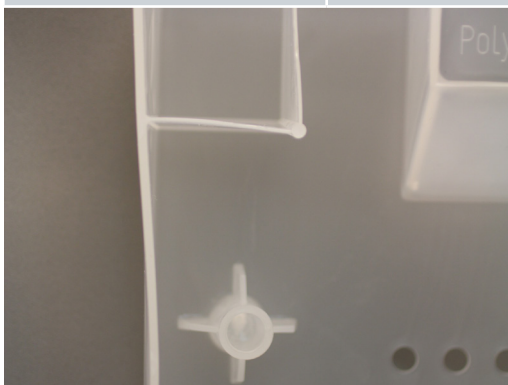

Weld Lines

Root cause: Plastic flowed around a feature and has 'welded' back together.

| SOURCES | | | |
|-------------------------|------------------------|---------------|---------------------------|
| Mold | Machine | Material | Process |
| Impaired venting | Heater band burned out | Contamination | Injection speed too low |
| | Leaking check ring | New lot | Hold pressure too low |
| | | | Transfer too high |
| | | | Melt temperature too low |
| RECOMMENDED ADJUSTMENTS | | | |
| Check vents | | | Increase mold temperature |
| Change gating location | | | Increase melt temperature |
| Increase wall thickness | | | Increase injection speed |
| | | | Increase hold pressure |
| | | | Increase hold time |



APPENDIX

INJECTION UNIT

The injection unit is comprised of three main pieces, the screw, barrel, and hopper.

The screw can be broken down into a few different sections, each having a specific goal in the process. Most injection molding machines use a reciprocating screw. A reciprocating screw rotates to build a shot. This rotating is what helps melt and mix the material making it a homogeneous melt. The heater bands on the barrel provide heat to help promote melting, but it is the shear heating of the plastic that actually melts the pellets. The shear heat comes from shearing the material.

The screw is comprised of three main sections, the feed zone, compression zone, and metering zone. The feed zone, where the channels are deep are moving the plastic towards the warmer zones located in the middle of the screw. The second area is called the compression zone, which is warmer than the feed zone and the screw channels are smaller in order to rotate the material. This rotation is shearing the material, which is pulling and stretching the material causing the plastic layers to flow past each other. When the layers flow past each other, there is a considerable amount of friction created. This friction is referred to as shear heating, which is what actually melts the pellets. The last section is the metering zone, which melts and mixes the material. The compression ratio of a screw is the ratio of the feed zone channel depth to the metering zone channel depth. This compression ratio is what helps build the shot size at the front of the screw. There is a check ring at the front of the screw and as the screw is rotating, the plastic pressure pushes the check ring forward allowing a shot of plastic to be built at the front of the screw. It is the pressure of the shot of plastic that overcomes the back pressure of the screw, and causes it to move backwards.

This shot of plastic is what will be injected into the mold during the injection phase.

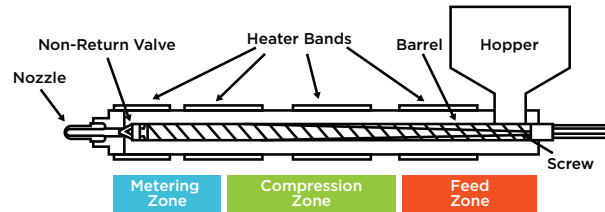

FIGURE 49 - The Injection Unit

NON-RETURN VALVES

Check Ring

The check ring insures that material cannot flow back over the screw tip upon injection. The ring slides back against a seat to seal off. When the screw is rotating the plastic pressure pushes the ring forward to allow material to flow through the flutes. The blue arrows show the flow of material in figure 51.

Ball Check

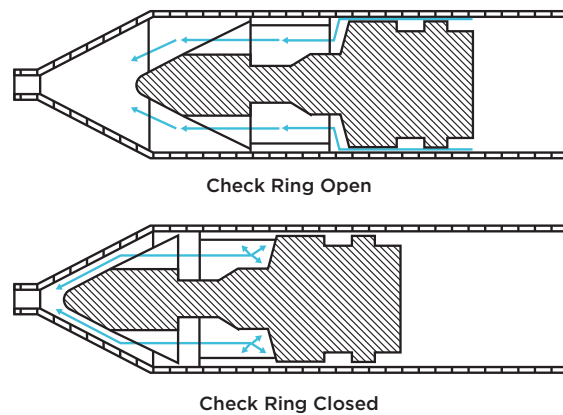

FIGURE 50 - Non-return Valve: Check Ring

This is also a type of non-return valve, where a ball is used to seal off the material instead of a ring. The ball is pushed back during injection, which stops material from flowing over the screw. Then upon screw recovery the plastic pressure pushes the ball forward and allows material to flow around it. This type of non-return valve seals faster than a check ring, but it also has a more restrictive flow path for the material.

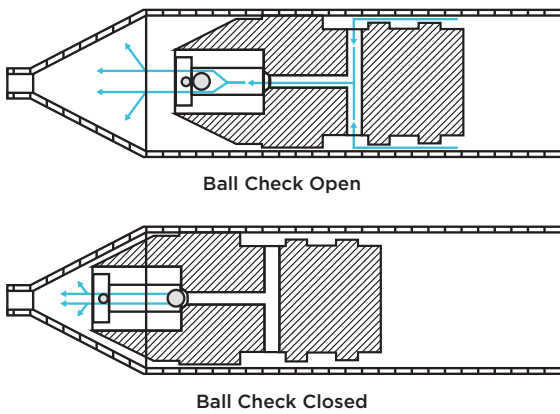

FIGURE 51 - Non-return Valve: Ball Check

Poppet Valve

The final type of non-return valve is called a poppet valve. The poppet is forced back during injection to seal off the material. Then upon screw recovery the poppet moves forward due to plastic pressure allowing the material to flow around the poppet. This type of non-return valve also seals off quicker than a check ring, and also has a more restrictive flow path.

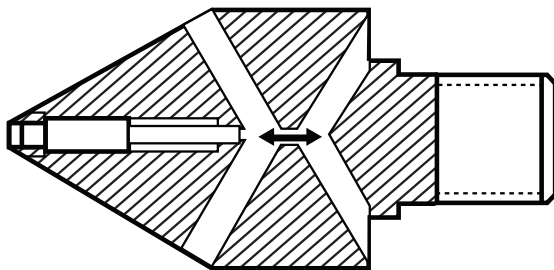

FIGURE 52 - Non-return Valve: Poppet Valve

NOZZLE TYPES

The purpose of a nozzle is to be an adaptor from the barrel to the mold. It is used to prevent metal or unmelted pellets from entering the mold. It provides additional mixing to the melt, which is especially helpful when using colorants.

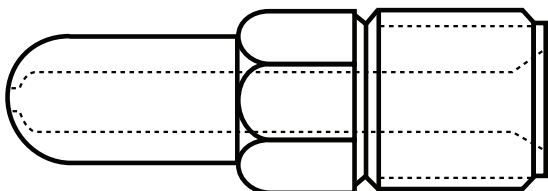

FIGURE 53 - General purpose nozzle

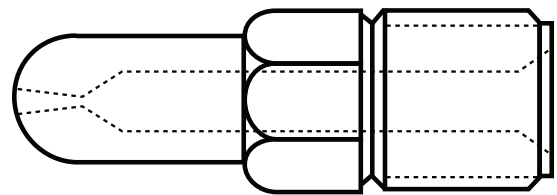

FIGURE 54 - Nylon nozzle

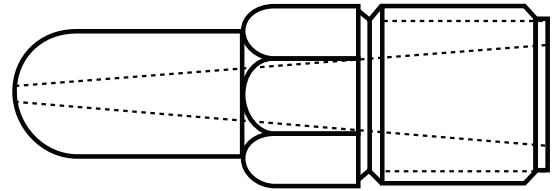

FIGURE 55 - Reverse Taper nozzle

IMPORTANT ADVICE

Screw Tip Breakage

The primary cause is not enough “soak” time. “Soak” time is what is referred to as the time it takes for the screw to heat up once the barrel is at the set temperature. Just because the barrel temperatures are at the set values, does not necessarily mean the screw temperature will be the same. Allow extra time for the screw to come to equilibrium with the barrel before processing.

Back Pressure

This is the pressure applied to the back of the screw to resist screw recovery after injection. A higher back pressure will cause an increase in the homogeneity of the melt, and also increase the melt temperature. However, too much shearing can cause damage to the molecular chains, and degrade the material.

THE CLAMPING UNIT

The clamping unit of a machine has three main functions: move the mold, hold the mold closed during injection, and provide a means of ejecting the part.

Types of Clamping Units

Hydraulic

Hydraulic clamping units work by having the load pass through a column of oil; the length of this column of oil is equal or greater than the stroke of the clamp.

The clamp force of the machine is directly proportional to the applied oil pressure, and the available clamp stroke of the machine can be figured out using the maximum daylight and the mold height.

Advantages

- Clamp force directly behind mold
- Larger opening strokes
- Clamp force can be easily changed
- Easy access to components for maintenance
- Reproducibility is easier on this machine

Disadvantages

- Louder
- Oil spill

Mechanical

Clamping force is proportional to actuating force and stiffness of the clamp. This is why a mechanical unit should never be left clamped together; as it results in more wear on the machine and reduced stiffness in the clamping unit. The available clamp stroke is a function of the toggle mechanism.

Advantages

- These machines have an automatic mold slow-down at clamp
- Stiffer clamp (spring factor)
- Faster traversing
- More energy efficient

Disadvantages

- Higher maintenance
- Reduced control over clamp pressure
- Measured by distance of clamping unit
- More difficult to vary clamp pressure
- Need to change position of moveable platen
- Clamp pressure delivered to outside of mold
- Limited opening strokes

Hydro-Mechanical

Load path passes through a column of oil. The stroke of the clamp is always greater than the length of the column of oil. The clamp force is directly proportional to the applied oil pressure. The available clamp stroke is a function of actuator stroke.

Advantages

- Combines both a mechanical and hydraulic unit

Disadvantages

- Expensive & difficult to maintain

Elements of a Clamping Unit

Stationary Platen

The platen supports the “A” half of the mold, which is also the stationary half. In the diagram, it can be seen that is the platen closest to the injection unit, and it provides a mean of contact between the injection unit and the mold. This platen does tend to deflect around the mold when clamp force is applied.

Movable Platen

This platen supports the “B” half, or the movable half of the mold. It also has a means of opening the mold and ejecting the part. It moves on spring steel rails to supports the weight of the mold. This platen also tends to deflect around the mold during injection.

Rear Platen

Older machines have a rear platen which supports the clamping mechanism. The position of this platen will change when using a mechanical clamping unit, so that clamp tonnage can be applied.

Tie Rods or Tie Bars

These are the major tension elements in the load path. The tie bars are threaded and held with a nut. The thread on the nut is important because it will determine what type of fatigue failure could occur. All of the tie bars in the system need to be calibrated to the same amount of pre-load. The tie bars stretching is what determines the amount of clamp tonnage is available to the machine.

Calculating Tie Bar Stretch

Four main formulas are needed to calculate tie bar stretch. The modulus of steel is 3 x 10⁷ psi.

- Area = πr^2
- Stress (σ) = Force (F) / Area (A)
- Strain (α) = Stress (σ) / Modulus (E)
- Change in Length (ΔL) = Length (L) * Strain (α)

MOLD DESIGN GUIDELINES

Layout Design

A & B Plate thicknesses are determined by the depth of the part geometry plus 3 times the water line thickness (Usually .375").²

Support Plate Thickness

Use recommended plate from mold base selection, add support pillars if deflection or stress is too high.

Mold Base Width

The "Cheek" width is the width between the edge of the part and the side of the mold base.

The "Cheek" is equal to the cavity depth, or 3 times the water line thickness, whichever is greater.

The total Mold Base Width = Cheek + Part Width + Contact Width (.500") + Space between cavities.

The space between cavities should be tight but wide enough for runners and ejectors.

Ejector Housing

The ejector housing height is equal to part height.

Types of Layout Designs

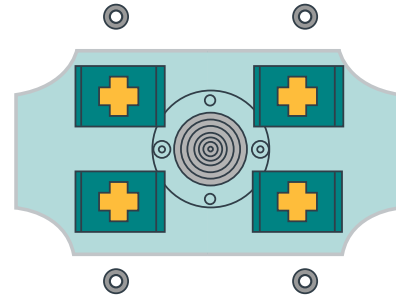

FIGURE 56 - Grid

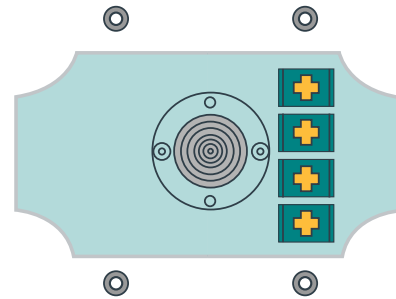

FIGURE 57 - Series

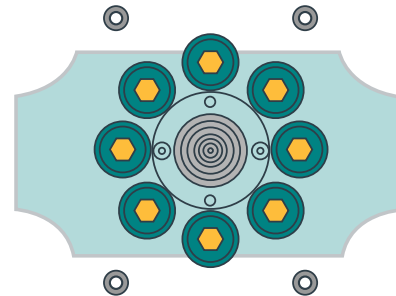

FIGURE 58 - Radial

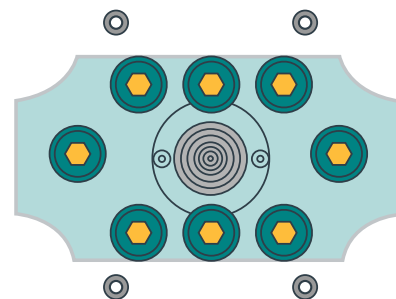

FIGURE 59 - Hybrid

Mold Strength

When consulting how strong the mold needs to be, there are two types of pressures it must withstand: injection pressure and clamping pressure.

Injection Pressure

This type of pressure is a result from the injection force of the plastic. It can be calculated using the projected area of the part and runner. The projected area of the part is the area that is directly trying to force the mold halves apart.

Dynamic Pressure

This is the pressure upon injection that is caused by the plastic filling the cavity. This pressure is high at the gate area and low at the end of fill. This pressure will drop dramatically when the part starts to reach the end of fill. When consulting how strong the mold needs to be there are two types of pressures it must withstand; injection pressure and clamping pressure.

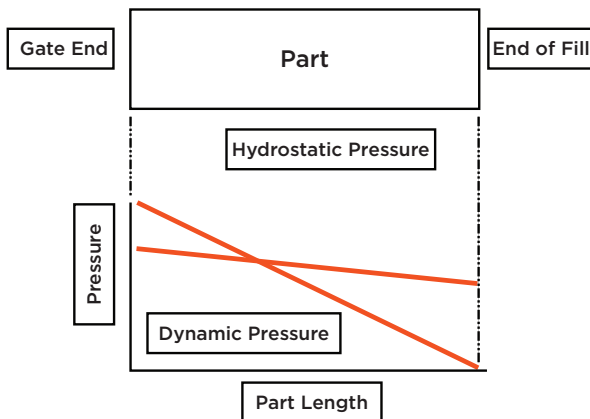

FIGURE 60 - Pressure vs Part Length

Hydrostatic Pressure

This is the pressure when the cavity is almost full and the machine enters the packing phase. This type of packing is what gives the part a good surface finish. The pressure remains fairly constant throughout the length of the part. The force in the equation comes from the calculated projected area of the part. The projected area can be used to find the overall clamp force that is required by the part.

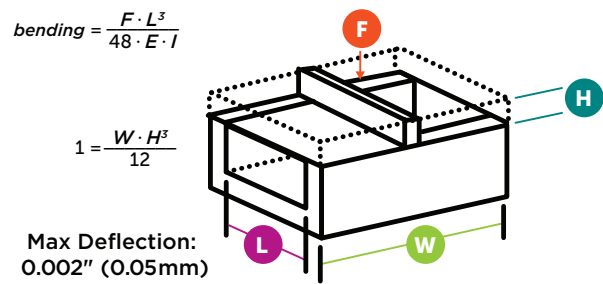

FIGURE 61 - Deflection equations

DETERMINING COOLING TIME

Step 1 - Part Cooling Time

The first step is to calculate the cooling time of the part itself.²

- T_{Melt} = Temperature of the molten plastics

$$t_c = \frac{h^2}{\pi^2 \cdot a} \ln \left(\frac{4}{\pi} \cdot \frac{T_{\text{melt}} - T_{\text{coolant}}}{T_{\text{eject}} - T_{\text{coolant}}} \right)$$

FIGURE 62 - For Plate Shaped Parts

$$t_c = \frac{D^2}{23.1 \cdot a} \ln \left(1.6 \frac{T_{\text{melt}} - T_{\text{coolant}}}{T_{\text{eject}} - T_{\text{coolant}}} \right)$$

FIGURE 63 - For Cylindrical Shaped Parts

- T_{Coolant} = Thermolator temperature
- T_{Eject} = Temperature the parts can eject without deforming
- H = Thickness (Use thickest portion of part)
- α = Thermal diffusivity

Thermal diffusivity can be calculated using the equation below.

- k = Thermal Conductivity Constant

$$a = \frac{k}{\rho * C_p}$$

- ρ = Density
- C_p = Specific Heat

Step 2 - Heat Transfer

The next step is to calculate the heat transfer rate. This is the total energy that needs to be removed from the part.

$$Q_{moldings} = m_{moldings} \cdot C_p \cdot T_{me} \cdot C_{plt} - T_{eject}$$

FIGURE 64 - Heat Transfer Equation

- $M_{Moldings}$ = Combined mass of molded parts
- C_p = Specific Heat of the material

Step 3 - Heat Removal Rate

$$\dot{Q}_{line} = \frac{\dot{Q}_{cooling}}{n_{lines}}$$

FIGURE 65 - Total Cooling for Mold

$$\dot{Q}_{cooling} = \frac{\dot{Q}_{moldings}}{t_c}$$

FIGURE 66 - Cooling Required by Each Line

- N_{lines} = The total number of independent cooling lines there are in the mold
- t_c = The cooling time required by the part (Determined in step 1)

Step 4 - Coolant Volumetric Flow Rate

$$\dot{V}_{coolant} = \frac{\dot{Q}_{line}}{n_{max, coolant} \cdot P_{coolant} \cdot C_{p, coolant}}$$

FIGURE 67 - Volumetric Flow Rate Equation

- $\Delta T_{Max, Coolant}$ = Change in coolant Temperature During Molding (1°C)
- $\rho_{Coolant}$ = Density of coolant
- CP = Specific heat of coolant

Step 5 - Determine Cooling Line Diameter

$$D_{max} = \frac{4 \cdot P_{coolant} \cdot V_{coolant}}{\pi \cdot \mu_{coolant} \cdot 4000}$$

FIGURE 68 - Max Diameter Equation

$$D_{min} = \sqrt[5]{\frac{P_{coolant} \cdot L_{line} \cdot V_{coolant}^2}{10\pi \cdot \Delta P_{line}}}$$

FIGURE 69 - Min Diameter Equation

- $\rho_{Coolant}$ = Density of coolant
- $V_{Coolant}$ = Volumetric flow rate of coolant
- $\mu_{Coolant}$ = Viscosity of coolant
- ΔP_{line} = Max pressure drop per line (Usually equals half of the pump capacity)
- L_{Line} = Length of the cooling lines

COOLING LINE SPACING

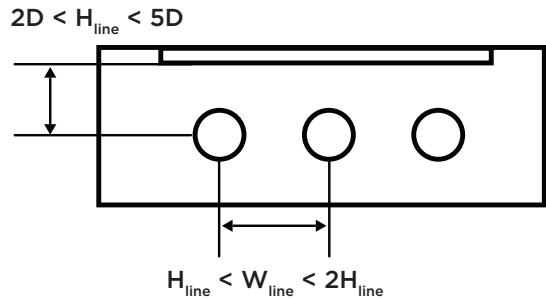

FIGURE 70 - Cooling Line Spacing

| ADHESIVE | ADVANTAGES | DISADVANTAGES |
|----------------------|--|--|
| Cyanoacrylate | Rapid, one-part process Various viscosities Can be paired with primers for polyolefins | Poor strength Low stress crack resistance Low chemical resistance |
| Epoxy | High strength Compatible with various substrates Tough | Requires mixing Long cure time Limited pot life Exothermic |
| Hot Melt | Solvent-free High adhesion Different chemistries for different substrates | High temp dispensing Poor high temp performance Poor metal adhesion |
| Light Curing Acrylic | Quick curing One component Good environmental resistance | Oxygen sensitive Light source required Limited curing configurations |
| Polyurethane | High cohesive strength Impact and abrasion resistance | Poor high heat performance Requires mixing |
| Silicone | Room temp curing Good adhesion Flexible Performs well in high temps | Low cohesive strength Limited curing depth Solvent sensitive |
| No-Mix Acrylic | Good peel strength Fast cure Adhesion to variety of substrates | Strong odor Exothermic Limited cure depth |

Bibliography

1. PLET 350 – Plastic Part Design, Jason Williams, Spring 2014, Penn State Erie, The Behrend College.
2. Kazmer, David. Injection Mold Design Engineering. Munich: Hanser, 2007. Print.
3. Beaumont, John P. Runner and Gating Design Handbook: Tools for Successful Injection Molding. 2nd ed. Munich: Hanser, 2007. Print.
4. Beaumont, John P., R. L. Nagel, and R. Sherman. Successful Injection Molding: Process, Design, and Simulation. Munich: Hanser, 2002. Print.
5. Osswald, Tim A., Lih-Sheng Turng, and Paul J. Gramann. Injection Molding Handbook. 2nd ed. Munich: Carl Hanser, 2008. Print.

Acknowledgments

Avient would like to acknowledge the gracious input provided by the faculty of the Behrend Plastics Engineering Technology program at Penn State University. Their help has been invaluable in the development of this guide.

www.avient.com



Copyright © 2020, Avient Corporation. Avient makes no representations, guarantees, or warranties of any kind with respect to the information contained in this document about its accuracy, suitability for particular applications, or the results obtained or obtainable using the information. Some of the information arises from laboratory work with small-scale equipment which may not provide a reliable indication of performance or properties obtained or obtainable on larger-scale equipment. Values reported as "typical" or stated without a range do not state minimum or maximum properties; consult your sales representative for property ranges and min/max specifications. Processing conditions can cause material properties to shift from the values stated in the information. Avient makes no warranties or guarantees respecting suitability of either Avient's products or the information for your process or end-use application. You have the responsibility to conduct full-scale end-product performance testing to determine suitability in your application, and you assume all risk and liability arising from your use of the information and/or use or handling of any product. AVIENT MAKES NO WARRANTIES, EXPRESS OR IMPLIED, INCLUDING, BUT NOT LIMITED TO, IMPLIED WARRANTIES OF MERCHANTABILITY AND FITNESS FOR A PARTICULAR PURPOSE, either with respect to the information or products reflected by the information. This literature shall NOT operate as permission, recommendation, or inducement to practice any patented invention without permission of the patent owner.